

Childproof Faucet Cover for URS of Dayton

Team 2

Joshua A., CJ Nesbit, Guillermo P., John T.

University of Dayton

School of Engineering

EGR 103 – Section 01

11/20/2024

Abstract

The objective of this project is to construct a childproof gooseneck sink faucet cover for children's classrooms at URS of Dayton. The students need to be prevented from tampering with the faucet during class times, but the faucet still needs to be readily available for teachers to utilize. The gooseneck faucet is twelve inches (one foot) from the ends of the left to right handles when in the off position. The base of the sink to the top of the handles measures four inches. Multiple different approaches were brainstormed, including strategies such as covering the entire volume of the sink with a solid material, interlocking just the handles of the sink, using AI and other technologies to mechanically disable the sink, and finally, adding a physical deterrent to children touching the sink. The resources available to produce a final product were limited – a \$75.00 USD budget was provided, as well as access to basic 3D printing and welding.

I. Introduction

The United Rehabilitation Services of Greater Dayton serves both children and adults affected by disabilities or other special needs. URS has several adult volunteers who service those affected by teaching, daycare, nursing services, speech therapies, and much more. However, URS needs to childproof their gooseneck sink faucets such that teachers can still readily access the sinks, while the children are prevented from playing with them during class time. The URS disclosed that the age range of the children is anywhere from as young as six years old to seventeen years old. URS has also stated that most of the simple baby locks they own currently are effective, but none are designed to situate the gooseneck faucet.

II. Generation of Design Alternatives

Our team focused on generating a large spectrum of ideas that covered different types of solutions. At first, we generated zany ideas that would likely result in lawsuits. For example, our first idea was electrocuting the sink (“Touch Resistant”) such that it would strongly shock any children who touched the handle. Following that line of thinking, we also considered a design that would use face-recognition artificial intelligence connected to a flyswatter on a motor (“This is What AI Was Made For”). It would physically assault the children if they got within range of the flyswatter. Neither of these would be a good idea as it could cause physical damage to the children, some of which are as young as six years old. In the realm of more realistic possibilities, we considered covering the sink handle in totality with plastic that would be locked with a normal baby lock, like bread box, which is what we named the design. This has the potential of not being an effective solution for the students who are already able to open most standard baby locks. Our last design we generated was found by researching advanced childproof locks on the

internet. A common solution to childproofing door handles was a multi-layered interlocking mechanism that would require high dexterity and understanding to open, which would not be possible for most children in a reasonable timeframe. This line of thinking produced the “Blocks” design, which consisted of two interlocking blocks that would slide over the handles and attach to each other, limiting horizontal movement. This design was planned to be fully made with 3D-printing, mostly with plastic filament, but perhaps steel filament if the prototype proved to be effective.

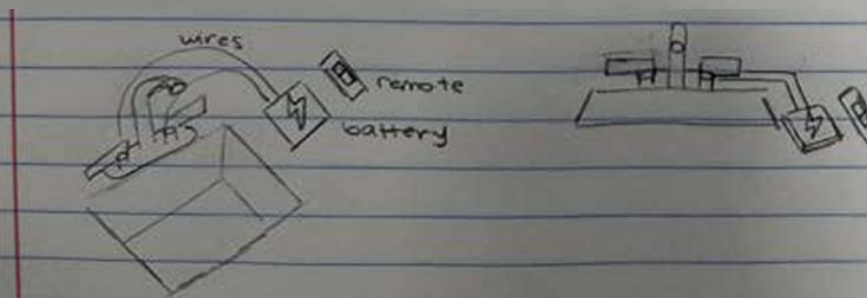
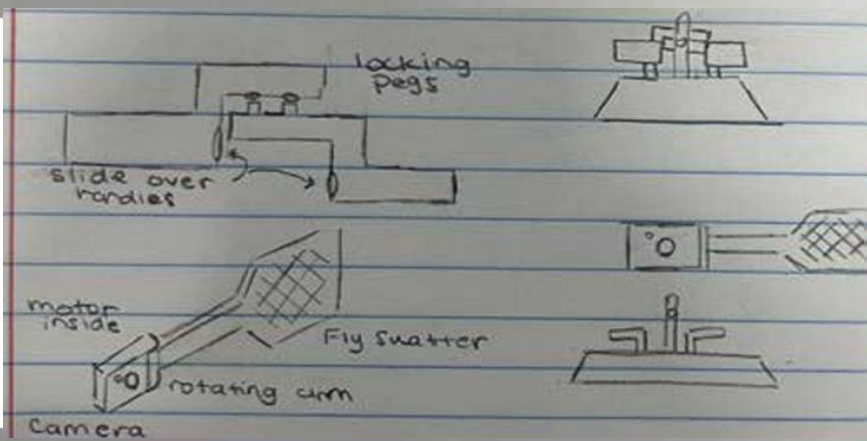
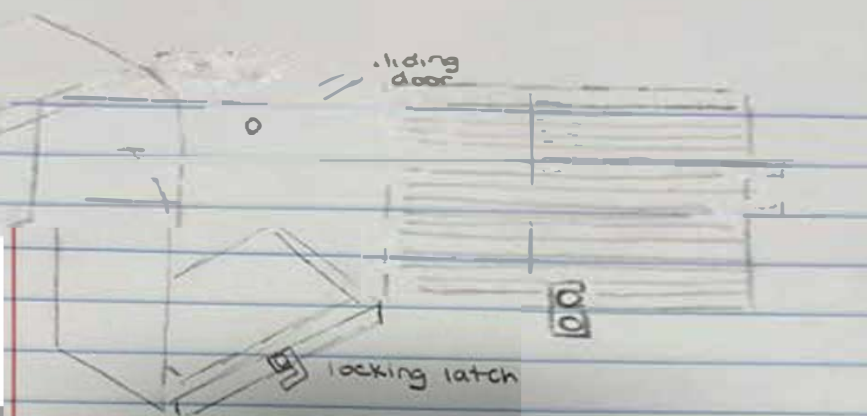

III. Design Selection Process

Considering the cost requirements, the resilience required in an environment of children, and ethical standards, the final design candidates were narrowed down the design selections to “Blocks” and “Bread Box”. The final design had to be the best candidate in a variety of different important factors, including complexity, size, reproducibility, ease of access, and strength. In the end, the “Blocks” design was proven supreme. It included two (or three, if the baby lock was utilized) layers of complexity, in comparison to just one for “Bread Box”. In terms of reproducibility, the “Blocks” design was both smaller and less material to manufacture. The size also made it easier to mass produce, despite this not being a main point of concern. In terms of ease of access, the “Blocks” design takes longer, but the time investment is so insignificant (~10 seconds difference), that it was not a main point of consideration. Finally, in terms of pure strength, the “Blocks” design was more compact and smaller, meaning it would be more likely to sustain high force loads. After considering all these factors, it became clear that the “Blocks” design was the optimal choice.

(Table out of 5)	Blocks	Bread Box
Complexity of Design	3	1
Size/Ease of Applying	5	4
Reproducing the Design	5	3
Ease of Using the Design	4	5
Strength of the Design	4	3
TOTAL:	21	16

IV. Final Design

The final design “Blocks” was designed and prototyped using the popular software package “SolidWorks”. The final design was made to immobilize the handles, using a slipcover design which allowed the design to slip over the covers and clip together in the center. The clipping mechanism is offset from the cover part of the design, so it is usable with an inline handle spout design for use with the URS faucet and other similar faucet designs. The design also had gussets added to add extra support against torsional forces. This design also had rectangular holes in the top and bottom of the offset portion which would allow a baby lock to be used for an extra layer of complexity. The complexity was added so that it can be hard to open for varying needs of the end user. PETG was chosen for the design material because it is more ductile and flexible than PLA and is still easy to print.

03-01

DAYTON

100% Recycled
Kraft Paper
Recycling
Symbol
100% Recycled
Kraft Paper
Recycling
Symbol
100% Recycled
Kraft Paper
Recycling
Symbol







V (a). Testing the Design Qualitatively

The opportunity to receive physical test data at URS was not available, instead, it was tested by this group. To test this design, we used a torsion test. This test showed pressure points in the design and any faulty printing that may have occurred. The design, with the baby lock attached, was displaced in all three planes of direction: lateral, longitudinal, and vertical. For the scope of this section, lateral refers to movement in reference to the plane that defines the sink handles in the “Off” position. The longitudinal direction therefore refers to the plane that defines the direction between the sink and the user, and the vertical direction is defined by the direction of gravity when the sink is in the conventional upright position. In all cases, the displacement was exerted by a reasonably strong adult male. It is reasonable to assume therefore that the force applied will be much more than the device will normally be exposed to.

What is Being Tested:	How is it Being Tested:	How Does the Design Pass:
1. Lateral Stress	The sink with the applied design will be subjected to significant lateral displacement.	All pieces of the design stay connected and do not fracture, and the sink handles are prevented from turning into the “On” position. The design should also not lose any future functionality after the test.
2. Longitudinal Stress	The sink with the applied design will be subjected to significant longitudinal displacement.	Same as above.
3. Vertical Stress	The sink with the applied design will be subjected to significant vertical displacement.	Same as above.
4. Baby Lock Durability	The baby lock will be attached to the design and its performance will be averaged over the Tests #1-3.	The baby lock remains both intact and connected to the main design and does not impede the functionality of the design after the test.

V (b). Testing the Design Quantitatively

While a qualitative test is sufficient to prove the effectiveness of the final design, it is also useful to have quantitative data to help support the design's case. As mentioned in Section IV, the design was prototyped and modeled in the SolidWorks software package. Within the software, there is a tool named "SolidWorks Simulation" that allows the design to be stress tested, and a variety of different factors are calculated. For the stress test, force was applied in all three directions at the extremities of the device to produce maximum torque, and by extension, simulate the maximum possible strain. The design passes under two (2) conditions: It can sustain up to one hundred (100) pounds of force in all three directions without fracturing and, after the 100 pounds of force, it does not deform in the direction of the stress by more than one (1) centimeter. The design was simulated connected to itself but not attached to the sink. These environmental factors will be important in analyzing the design's results.

What is Being Tested:	How is it Being Tested:	How Does the Design Pass:
1. Lateral Stress	The design model will be subjected to significant simulated lateral displacement.	The design sustains a load of 100 pounds of force without fracturing and shows a maximum of one centimeter of deformation in the direction of the stress.
2. Longitudinal Stress	The design model will be subjected to significant simulated longitudinal displacement.	Same as above.
3. Vertical Stress	The design model will be subjected to significant simulated vertical displacement.	Same as above.

VI (a). Qualitative Results

Lateral Stress Test

The “Blocks” design was able to sustain significant lateral displacement while staying interconnected and not fracturing. This was expected as the design was anisotropic, being particularly strong in the lateral and vertical directions. The design was able to be applied and disappplied again after the duration of the test. Therefore, it is concluded that the design completely passes the Lateral Stress Test.

Longitudinal Stress Test

The first prototype of the “Blocks” design did not show favorable results to the Longitudinal Stress Test. The supporting corner of the female part of the design fractured, splitting the female part into two. After this structural failure, the design was still able to be applied and disappplied, but the overall functionality of the design was severely impaired. Therefore, the first prototype failed the Longitudinal Stress Test. The second prototype of the “Blocks” design printed more filament in the corner that showed structural weaknesses. The improved prototype was subjected to the same displacements, and did not show structural failure. After the test the design was still as functional as before. Therefore, while the first prototype failed, the final prototype passed the Longitudinal Stress Test.

Vertical Stress Test

This test was the least likely to fail. As mentioned before, due to the shape and nature of the design, the “Blocks” design is anisotropic and is particularly strong in the lateral and vertical directions. The design easily stayed intact during the duration of the test and did not lose any functionality after the conclusion of the test. Therefore, the design passes the Vertical Stress Test.

Baby Lock Durability Test

The baby lock remained intact and stationary for all three of the previous tests. It remained connected to the main design in the locked position and was able to be unlocked and detached from the design afterwards, meaning it did not impede the functionality after the test. Therefore, the baby lock successfully passed the Baby Lock Durability Test.

Tabulated Summary of Test Results

What is Being Tested:	Pass/Fail:	Additional Notes:
1. Lateral Stress	Pass	This test is important as it is indicative of the overall cohesiveness of the two independent parts of the design.
2. Longitudinal Stress	Fail, then Pass	The first prototype of the design failed. The next prototype reinforced the point of failure to ensure success of the design. The reinforced design passed.
3. Vertical Stress	Pass	The design easily passed the test, and the test is also not a point of concern as the design is arguably strongest in this direction.
4. Baby Lock Durability	Pass	The baby lock plays an integral role in ensuring additional complexity to the applied design, so this test is important for the quality and effectiveness of the design.

VI (b). Quantitative Results

Lateral Stress Test

This simulation was done in the opposite direction of normal use and it had a total displacement of 2.8 cm at 100 lbf of force which may sound bad. Still, the forces would be much less overall force on the handles because the design transfers the force into the sink handle if deformed over 5 mm. The yield strength of PETG is around 58 Mpa which is about 2 times the force at 5mm of displacement. This failed by itself but would likely succeed if it were tested with handles inserted.

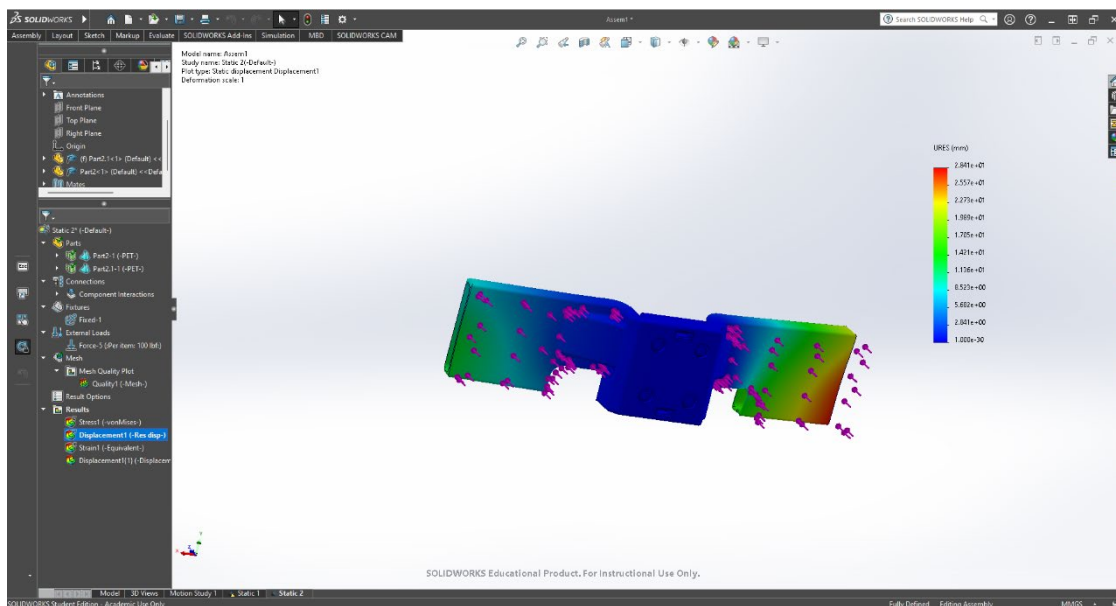

Longitudinal Stress Test

This simulation is in the direction that it will most likely have force applied. In this direction, it deformed 4.3 cm at 100 lbf. which is a greater displacement than the lateral simulation but again the design will be restrained in actual use where it is restrained to only allow 5 mm of displacement which would only produce a maximum of 25 Mpa which is well below PETG's Yield force.

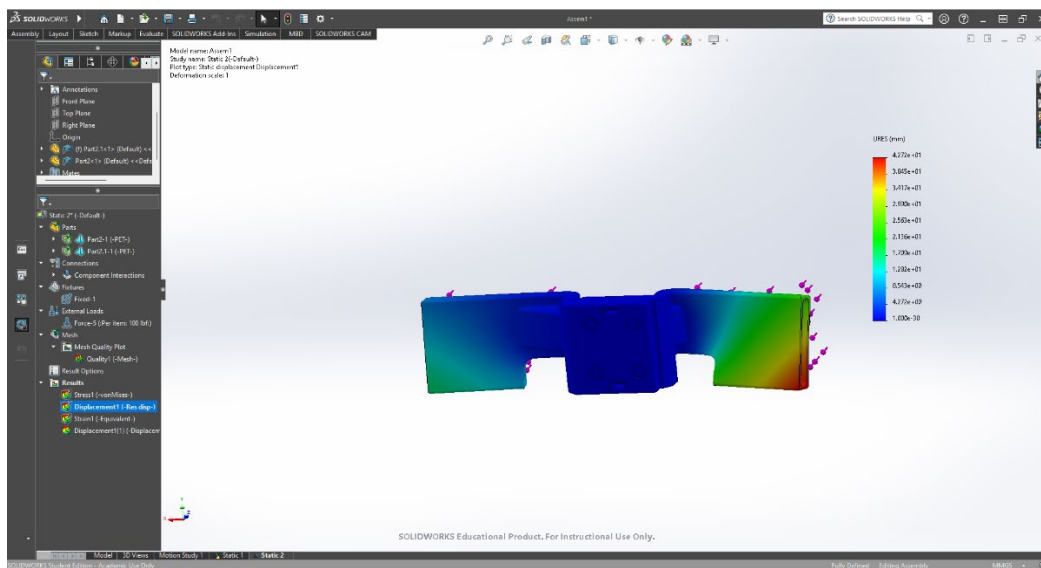

Vertical Stress Test

This simulation failed at 100 pounds exceeding 1 cm of displacement and 323 Mpa. This force was concentrated in one spot in the corner which can be seen in the image below. This type of force would create a torsional force which would have been prohibited by the design of the handle. So, this test when on the faucet would likely pass because the handle would have the majority of the force transferred to it.

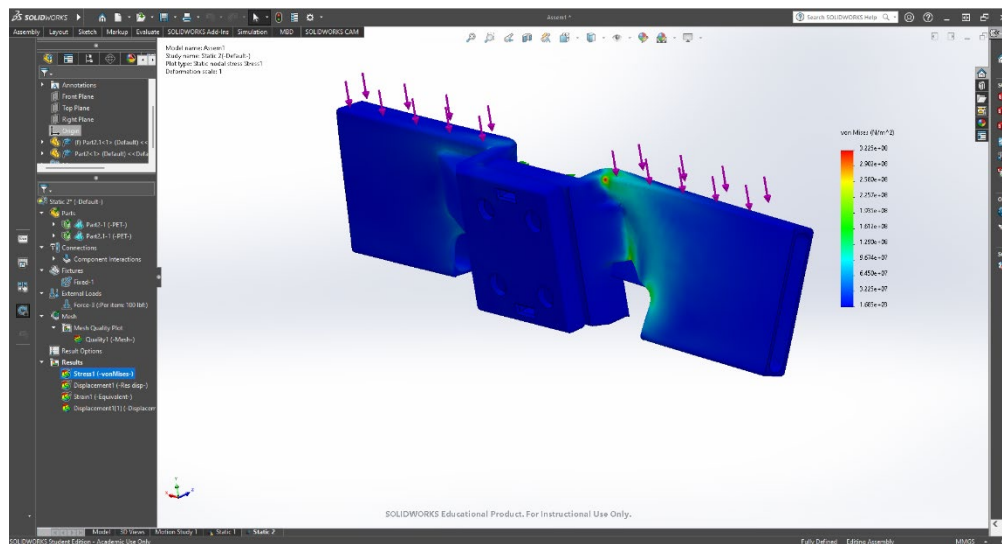

Tabulated Summary of Test Results

What is Being Tested:	Pass/Fail:	Additional Notes:
1. Lateral Stress	Fail*	At 100lbs it deformed 2.8 cm And deformed 1cm at 35 lbf.
2. Longitudinal Stress	Fail*	At 100lbs it deformed 4.3 cm And deformed 1cm at 25 lbf.
3. Vertical Stress	Fail*	At 100lbs it deformed 2.9cm And deformed 1cm at 55 lbf.

*As mentioned before, it is important to note that the ‘failure’ of the design does not necessarily reflect how it would behave when attached to the sink. In addition, the design was only displaced, and never failed, considering the maximum extension on the most flexible plane was 43 millimeters or 4.3 cm.

VII. Conclusion

The “Blocks” design met and exceeded all expectations for a strong, complex, and accessible childproof cover for a gooseneck faucet. “Blocks” supported significant stress in all three dimensions while still covering and locking the sink; being an excellent indication of the design’s viability. The design is easily accessible, taking only two/three steps to assemble and disassemble. These steps in total take around twenty seconds and require relatively high dexterity and hand-eye coordination. Considering the design’s sturdiness, complexity, ease of access, dexterity requirements, easy bulk manufacturing, and size, “Blocks” is an exceptional candidate for a childproof gooseneck sink faucet cover.

The qualitative results when attached to the sink prove that the design can withstand significant force and displacement without losing structural integrity or function. Resources to quantitatively test the design in this modality of being attached to the sink were unfortunately not available.

While the design ‘failed’ the quantitative tests, it was not a surprise. When attached to the sink, the design would transfer much of the force to the sink, reducing displacement. In addition, the design also demonstrated impressive flexibility by deforming up to 4.3 centimeters without fracturing. Finally, there is always some uncertainty in the results, as the quantitative tests were simulated, meaning any number of software errors or inaccuracies could affect the results.

VIII. Recommendations

The design is currently optimal for the conditions that were provided by URS. However, in the future, if additional information or factors are provided, it would be appropriate to revise and change the design. For example, if it is found that the children can fracture the design with hard tools like metal hammers, printing the design using a stronger material such as stainless steel could be considered. If the current baby lock design is not secure enough and a more complex one is found to better fit, then the baby lock attachment points should be redesigned to allow for the superior option.

If possible, the design should also be quantitatively tested in a more rigorous way than software simulation. This would guarantee the quality of the design. If the device were to fail a rigorous quantitative test in any way, any of the solutions above should be strongly considered. If the device failed simply due to the force exerted, then the design should be produced with a stronger material.

Appendices

Software Packages Used

SolidWorks

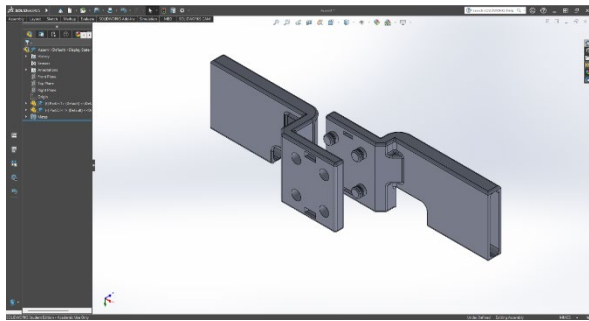

Figure 1: Credit-Joshua A.

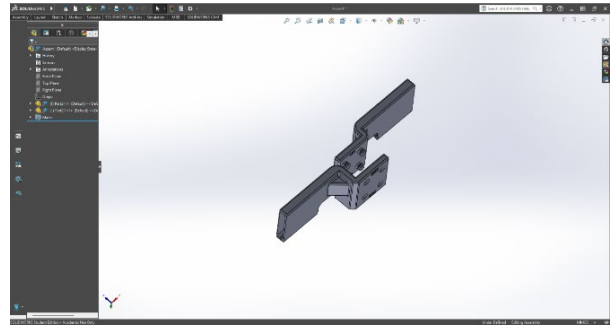

Figure 2: Credit-Joshua A.

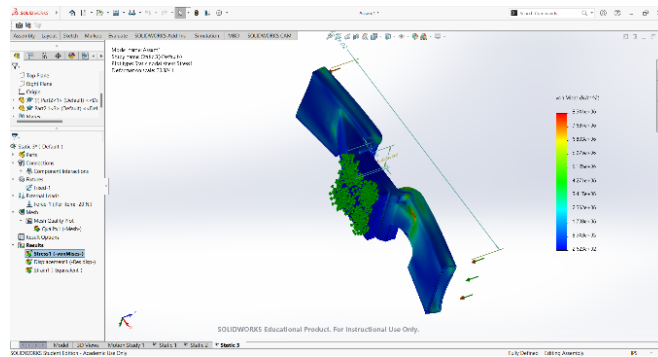

Figure 3: Credit-Joshua A.

Cura

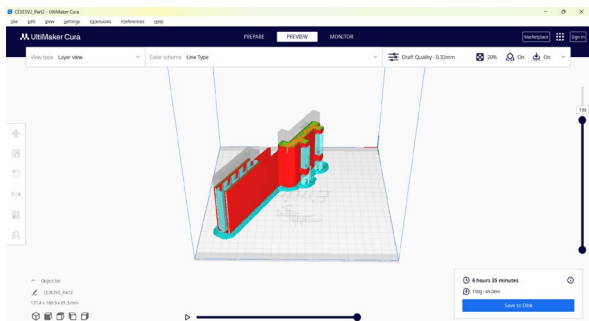

Figure 4: Credit-Joshua A.

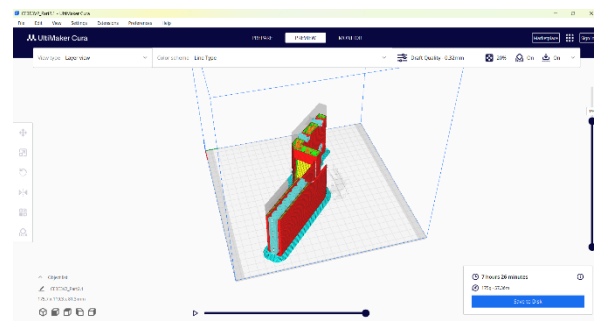

Figure 5: Credit-Joshua A.

Materials Used

Filament: PETG - Polyethylene Terephthalate Glycol - [PETG Filament Link](#)

Nozzle: Brass 8.0mm

Printer: Ender 3 V1

Lock: Baby Lock - [Baby Lock Link](#)

Unit Cost Analysis

Materials	Price per unit	Amount	Total Price	Price of Final Design
PETG Filament	.015 \$/g	166.7g	\$2.50	
Baby Lock	\$4.99	1 baby lock	\$4.99	
				\$7.49

Design References

[Amazon baby lock](#)